



- Disposable
- Single Use Only
- Latex Free
- Non-Sterile

The **HemoBandXL** is an adjustable, single-use band with a molded pressure pad. It is used for control of bleeding following needle removal. The band is designed for ease of use and patient comfort. The **HemoBandXL** also frees the dialysis staff from prolonged contact due to holding of needle sites. The band is wide to be comfortable to the patient while applying ample pressure for clotting of needle sites. The translucent plastic provides easy visualization of the needle site for ease in placement.

DFU: The **HemoBandXL** is used to provide pressure hemostasis of arterial, venous and dialysis access needle puncture sites.

WARNING: After placing **HemoBandXL**, check the graft for flow. A bruit must be detected to ensure graft patency. If a bruit is not heard the **HemoBandXL** should be loosened until the bruit returns.

CAUTION: Federal law restricts this device to sale by or on the order of a physician.

REF: Non-Sterile XL: HB-NSXL

**Package Contents: 24 HemoBandXLs
1 Instructions for Use**

HemoBand Corporation

515 N.W. Saltzman Rd. #797

Portland, OR 97229-6190 U.S.A.

1-800-297-8485 • FAX: 1-503-617-1823

www.hemoband.com

World wide patent pending
PATENT #: US 5,269,803

REV110325



Place a sterile bandage dressing over the puncture site. Place the **HemoBandXL** around the arm. Position the pressure pad so that the V-shaped groove is directly over sterile gauze dressing and the butterfly wings of the dialysis access needle. The end of the strap is inserted into the adjustable locking latch of the **HemoBandXL**. The band is gently tightened assuring that the pressure pad maintains its position over the needle. If the second **HemoBandXL** is to be used at the same time, apply a sterile gauze dressing to the second puncture site and place the second **HemoBandXL** around the arm at this time. The second **HemoBandXL** should be placed under the tubing of the first needle so as not to interfere with its removal. Again, position the **HemoBandXL** over the sterile gauze dressing covering the second needle site.

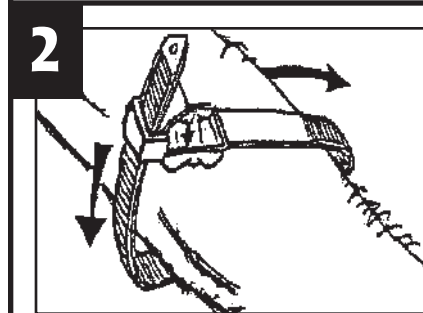

Prepare to remove the needle. Place your thumb into the recessed back of the pressure pad but do not apply pressure with your thumb while pulling up on the strap. With your thumb still on the pressure pad but not applying pressure, use your other hand to remove the needle. Any bleeding that may occur can be easily controlled with additional pressure from your thumb after the needle has been removed. Make adjustments to the band pressure as needed. Bleeding should now be controlled. Any fine adjustment of the **HemoBandXL** can now be made for patient comfort or persistent bleeding.

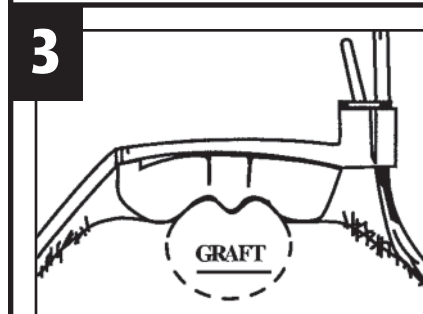

Check the graft for flow. This must be done to ensure that the graft has not been totally occluded. Using a stethoscope listen over the graft for a bruit. A bruit is the sound of blood rushing through the graft. It will sound like a whooshing noise with each heart beat. If a bruit is not heard the **HemoBandXL** should be loosened until the bruit returns. Most needle site bleeding will be controlled after five to ten minutes. It is recommended that you follow established holding times at your facility.

After hemostasis is achieved, the **HemoBandXL** may be removed. The band is removed by slowing loosening the latch.

Disinfection Protocol Prior To Use

NON-STERILE HEMOBANDS MUST BE DISINFECTED PRIOR TO USE

STAFF MUST WEAR GLOVES, PROTECTIVE EYEWEAR AND CLOTHING THAT COMPLY WITH ALL OSHA BLOOD BORNE PATHOGENS STANDARDS. THESE ARE RECOMMENDATIONS ONLY AND THE PRACTITIONER SHOULD REFER TO THE APPROPRIATE OSHA GUIDELINES FOR COMPLIANCE STANDARDS FOR YOUR FACILITY.

A specific disinfection protocol for the HB-NS/XL can be found on the back page of this directions for use. Using this disinfection protocol will assure that the HB-NS/XL has been processed using high level disinfection prior to use. A general protocol description is discussed in points 1-4 below.

1. Non-Sterile HemoBands are removed from the bag and place in an EPA registered hospital grade disinfectant with TB claim for the time indicated by the manufacturer to assure disinfection.
2. Let the Non-Sterile HemoBand soak the entire length of time recommended by the disinfectant manufacturer to assure disinfection.
3. After disinfection, using aseptic techniques the Non-Sterile HemoBands are rinsed with sterile water and used immediately.
4. After single use, dispose contaminated Non-Sterile HemoBands in your hazardous waste receptacle.

WARNINGS: Follow manufacturer's suggested monitoring and use protocols to assure effectiveness of the disinfectant. Prior to single use, test the HemoBand by inserting band into ratchet and pull firmly to test retention.

HOW TO USE CIDEX® SOLUTIONS

For over 40 years, CIDEX® Solutions have been safely used by health care professionals for the high level disinfection and sterilization of delicate heat-sensitive instruments because of their efficacy, materials compatibility, economy and ease of use. Follow these steps and refer to the specific CIDEX Solution label and package insert for complete instructions/information.

1 Don Personal Protective Equipment



Personal protective equipment must always be worn when handling contaminated instruments and equipment. Personal protective equipment includes disposable latex gloves, eye protection, face mask, and liquid-proof gown. Once personal protective equipment is donned, you are ready to begin the disinfection/sterilization process.

2 Clean Instruments

The first step in the disinfection/sterilization process is thorough cleaning.^(a) Contaminated instruments must be thoroughly cleaned prior to disinfection or sterilization since residual organic matter will decrease the effectiveness of the CIDEX Solution.

To remove debris, thoroughly clean all instrument surfaces and the lumens of hollow instruments (e.g. endoscopes) with a mild protein dissolving detergent such as ENZOL® Enzymatic Detergent.^(b)

CIDEX Solutions are compatible with enzymatic detergents (e.g. ENZOL Detergent) which are mild in pH, low foaming, and easily rinsed from instruments. Detergents that are either highly acid or alkaline are contraindicated as cleaning agents since improper rinsing could affect the efficacy of the CIDEX Solutions by altering their pH.



(a)

(b)



Following cleaning, rinse instrument surfaces and lumens with large amounts of fresh water to remove residual detergent.



Remove excess moisture from instrument prior to disinfecting or sterilizing. This will help prevent water from rapidly diluting the CIDEX Solution below its minimum effective concentration (MEC). Refer to instrument manufacturer's labeling for additional instructions on disassembly, decontamination, cleaning and leak testing.

3 Activate Solution



Once the instruments have been properly cleaned, you are now ready to begin using the CIDEX Solution. Prepare CIDEX Solution for use by first adding the entire contents of the activator vial to the solution in the container. Shake well. Activated solution immediately changes color to green, thereby indicating the solution is ready to use.

Do not use activated solution beyond stated 14 or 28 day reuse life.

NOTE: The activator contains a rust inhibitor. Do not add any other agent.



Record the date of activation (mixing date) and expiration date in the space provided on the CIDEX Solution container label, in a log book, or on a label affixed to the CIDEX Solution tray or any secondary container. Log books are available with our CIDEX Solution Information Station (Reorder #20251) or may be obtained through your local Advanced Sterilization Products sales representative.

4 Disinfection/Sterilization



Immerse clean instruments completely in the CIDEX Solution.

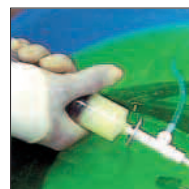

Fill all lumens of hollow instruments.



To reduce exposure to glutaraldehyde vapors which can be irritating, cover the CIDEX Solution tray or bucket with a secure lid. Soak instruments for the amount of time required for disinfection or sterilization. See label and package insert for complete instructions/information on soak times and temperature for disinfection and sterilization.

5 Rinsing Instruments



For devices that have been sterilized:

Remove instruments from solution using a sterile technique and rinse thoroughly with sterile water. See package insert for complete rinsing instructions/information.



For devices that have been disinfected:

Remove instruments from solution and rinse thoroughly with sterile water or potable tap water. The quality of rinse water used is dependent on the intended use of the instrument. See package insert for complete rinsing instructions/information. Refer to the instrument manufacturer's labeling for additional rinsing instructions.

6 Dry

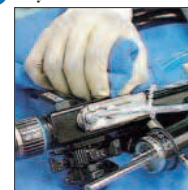

Dry the instruments. Disinfected or sterilized equipment should be used immediately or stored in a manner to minimize recontamination. See package insert for complete instructions/information on drying flexible endoscopes when using potable water for rinsing. Refer to the instrument manufacturer's labeling for additional storage and/or handling instructions.

7 Testing



It is important to note that CIDEX Solutions may expire prior to the reuse date stated on the label.¹ Do not rely solely on days in use. To determine if the MEC of the CIDEX Solution is still present, CIDEX Solutions must be tested prior to each use with the appropriate CIDEX Solution Test Strip.

8 Disposal



In compliance with the United States Environmental Protection Agency requirements, CIDEX Solutions may be disposed of as an ordinary domestic waste rather than a hazardous waste. However, some state regulatory and local water board or sewer authorities may have certain restrictions on drain disposal of specific wastes from your facility.

For technical information on CIDEX Solutions, contact your local Advanced Sterilization Products sales representative or call ASP customer support at 1-888-783-7723.

¹CIDEX Solutions label reuse claims are based on an EPA protocol which challenges the solution three times per day in manual systems. Many health care workers challenge CIDEX Solutions more than three times per day or use CIDEX Solutions in scope washers. These practices cause dilution of the solution prior to its stated use life.

